



INSPIRE

Infrastructure for Spatial Information in Europe

Position Paper on the Implementing Rules for INSPIRE Services allowing Spatial Data Services to be invoked (Invoke Spatial Data Services Services)

Drafting Team “Network Services”

| | |
|--------------------|--|
| Title | Position Paper on the Implementing Rules for INSPIRE Invoke SDS Services |
| Creator | Network Services Drafting Team |
| Date | 2011-10-08 |
| Subject | Implementing Rules for Invoke SDS Services |
| Status | Version 3.0 after incorporating comments from National Contact Points and the National Contact Point Workshop at the INSPIRE conference 2011. |
| Publisher | Network Services Drafting Team |
| Type | Text |
| Description | This document identifies Scope, Technologies, Issues and Time Table towards the development of the implementing rules for Invoke SDS Services to fulfil the INSPIRE directive. |
| Format | MS Word (doc) |
| Source | Network Services Drafting Team |
| Rights | INSPIRE DT members. |
| Identifier | Position Paper IR Invoke SDS Services |
| Language | EN |
| Relation | Not applicable |
| Coverage | Project duration |

Table of contents

- 1 Introduction..... 3**
- 1.1 Background 3
- 1.2 The Directive’s Requirements for Invoke SDS Services..... 4
- 2 Aspects of INSPIRE Invoke SDS Services..... 4**
- 2.1 Scope of INSPIRE Invoke SDS Services..... 5
- 2.2 Analysis of potential technologies for INSPIRE Invoke SDS Services 8
 - 2.2.1 Possible technologies and tools 9
- 2.3 Operations and service quality requirements of an INSPIRE Invoke SDS Services 9
- 2.4 Quality of Service 12
- 2.5 Roadmap towards an Implementing Rule of INSPIRE Invoke SDS Services 12

| | | |
|--|---------------------------------------|--------------|
| Infrastructure for Spatial Information in Europe | Position Paper IR Invoke SDS Services | |
| | 2011-10-08 | Page 3 of 12 |

1 Introduction

This document contains the INSPIRE Network Services Drafting Team position paper on how to develop the draft proposal for Implementing Rules (IRs) on INSPIRE Invoke Spatial Data Services (SDS) Services as required by the INSPIRE Directive (2007/2/EC). This document has been provided for review by the National Contact Points and a National Contact Point Workshop to discuss the content that has been held at the INSPIRE conference 2011. This Version 3.0 tries to consider all comments and change suggestions that have been put forward and agreed upon in the mentioned workshop.

This document is published on the INSPIRE web site ¹.

Please note: The INSPIRE Directive does not use the term *Invoke SDS Services* but '*services allowing spatial data services to be invoked*'. However, for readability reasons within this position paper *Invoke SDS Services* is used as the term to express this phrase.

The document is organised as follows: Section 1 is introductory to help readers understand the background and requirements without the need to reference other documents. In Section 1.1 general background information is given for the INSPIRE Network Services Implementation Rule development. Section 1.2 presents the requirements for an Invoke SDS Service as given by the INSPIRE Directive.

Section 2 is the core of this discussion paper and presents the positions on the following aspects:

- scope of INSPIRE Invoke SDS Services and relation to other INSPIRE Services and Implementing Rules,
- Standards and Technologies to be considered,
- operations, potentially to be considered in the interface of an INSPIRE Invoke SDS Services
- quality of service requirements on INSPIRE Invoke SDS Services
- a roadmap for the development of the INSPIRE Invoke SDS Services

Sections on each of the forenamed aspects will have to include a discussion on related technical or organisational issues.

1.1 Background

INSPIRE is a Directive (2007/2/EC) of the European Parliament and of the Council establishing an Infrastructure for Spatial Information in the European Community². The purpose of such an infrastructure is to assist policy-making in relation to policies and activities that may have a direct or indirect impact on the environment. The Directive came into force on the 15th May 2007.

INSPIRE should be based on the infrastructures for spatial information that are created by the Member States (MSs). Such infrastructures should be designed to ensure that spatial data are stored, made available and maintained at the most appropriate level; that it is possible to combine spatial data from different sources across the Community in a consistent way and share them between several users and applications; that it is possible for spatial data collected at one level of public authority to be shared between other public authorities; that spatial data are made available under conditions which do not unduly restrict their extensive use; that it is easy to discover available spatial data, to evaluate their suitability for the purpose and to know the conditions applicable to their use.

To achieve these aims, the Directive focuses in particular on five key areas: metadata, the interoperability and harmonisation of spatial data and services for selected themes (as described in Annexes I, II, III of the Directive); network services and technologies; measures on sharing spatial data and services; and coordination and monitoring measures.

¹ INSPIRE Website: <http://www.ec-gis.org/inspire/>

² The text of the Directive in multiple languages is available at <http://eur-lex.europa.eu/JOHtml.do?uri=OJ:L:2007:108:SOM:EN:HTML>

| | | |
|--|---------------------------------------|--------------|
| Infrastructure for Spatial Information in Europe | Position Paper IR Invoke SDS Services | |
| | 2011-10-08 | Page 4 of 12 |

Member States are required to bring into force national legislation, regulations, and administrative procedures necessary to comply with the Directive by the 15th May 2009.

To ensure that the spatial data infrastructures of the Member States are compatible and usable in a Community and trans-boundary context, the Directive requires that common Implementing Rules are adopted in a number of specific areas. These IRs will be adopted as Commission Regulations or Decisions, and will be binding in their entirety. The Commission is assisted in the process of adopting such rules by a Regulatory Committee composed by representatives of the Member States and chaired by a representative of the Commission (this is known as the Comitology procedure³). The Committee was established in June 2007.

The requirements of the Directive in relation to Invoke SDS Services are detailed below.

1.2 The Directive's Requirements for Invoke SDS Services

In the context of INSPIRE Invoke SDS Services, the following articles from the INSPIRE Directive are of major relevance and are quoted here for convenience reasons. The aforementioned articles define the scope and the role of Invoke SDS Services.

Article 4(3)

This Directive shall also cover the spatial data services relating to the data contained in the spatial data sets referred to in paragraph 1.

Article 11(e)

... services allowing spatial data services to be invoked. Those services shall take into account relevant user requirements and shall be easy to use, available to the public and accessible via the Internet or any other appropriate means of telecommunication.

Article 14(4)

In addition, where public authorities levy charges for invoke spatial data services, member States shall ensure that e-commerce services are available.

Article 7 (1)

Implementing rules laying down technical arrangements for the interoperability and, where practicable, harmonisation of spatial data sets and services, designed to amend non-essential elements of this Directive by supplementing it, shall be adopted in ...

Article 3, (4)

... 'spatial data services' means the operations which may be performed, by invoking a computer application, on the spatial data contained in spatial data sets or on the related metadata.

2 Aspects of INSPIRE Invoke SDS Services

The following discussion about the scope of the INSPIRE Invoke SDS Services also addresses the relation of the Invoke SDS Services towards INSPIRE Spatial Data Services and the other INSPIRE Network Services.

Further potential technologies for Invoke SDS Services and finally a roadmap for the further development of the INSPIRE Invoke SDS Service are presented in this chapter.

³ An explanation of the process for the development and adoption of the Implementing Rules is contained in Section 3 of the Work Programme 2007-09 see http://inspire.jrc.it/reports/transposition/INSPIRE_IR_WP2007_2009_en.pdf

| | | |
|--|---------------------------------------|--------------|
| Infrastructure for Spatial Information in Europe | Position Paper IR Invoke SDS Services | |
| | 2011-10-08 | Page 5 of 12 |

2.1 Scope of INSPIRE Invoke SDS Services

Within the definition INSPIRE Network Service Architecture⁴ the Invoke SDS Services has been introduced as one type of the INSPIRE Network Services. For the INSPIRE Network Service Architecture it is stated that:

- INSPIRE Network Services expose services for machine-to-machine communication. At least a workflow that follows the “publish – find – bind” design pattern should be possible.
- the INSPIRE Network Service Architecture is designed as Service-Oriented Architecture
- the default communication-protocol and binding technology for INSPIRE services should be SOAP.
- a set of Quality of Service requirements needs to be defined within each INSPIRE Network Service implementing Rule and needs to be fulfilled by a respective an INSPIRE compliant Network Service implementation
- for providing rights management functionalities a layered approach is taken (see GeoRM Layers in the figure) and that related standards and rules are considered being independent from the Network Service Implementing Rules and are therefore will not be defined within these Implementing Rules but in other e-government frameworks.

Consequently INSPIRE Network Services are considered as being Internet based services (normally Web Services as recommended by the W3C⁵) and any other way of telecommunication (as for instance phone calls or fax interconnections) is considered to be out of scope for the INSPIRE Invoke SDS Services Implementing Rule. However, as some of the current Standards, being applicable for INSPIRE Network Services lack a definition of a SOAP binding, current INSPIRE Technical Guidance Documents will have to also refer to Non-SOAP bindings.

Moreover this (consolidated) White Paper on Network Service Architecture describes the Invoke SDS Services as:

The “Invoke Spatial Data Service” service allows defining both the data inputs and data outputs expected by the spatial service and define a workflow or service chain combining multiple services. It also allows the definition of a web service interface managing and accessing (executing) workflows or service chains.

The “Invoke Spatial Data Services” service supports invoking individual (spatial) services as well as combinations of individual (spatial) services both synchronous and asynchronous, in service chains through a (web) service orchestration engine a.k.a. “workflow engine”. The service chains are expressed in a standard (e.g. XML-based) notation that can be consumed by commercial as well as open-source orchestration engines from multiple sources.

For spatial data services available on the Internet, the “Invoke Spatial Data Service” service will enable a user or client application to run them without requiring the availability of a GIS. This requires that a client application can discover the service, bind to it and invoke it. The orchestration/combination of Spatial Data Service with other services will require to precisely define the interactions between the services. Therefore, the interaction between the (spatial) services to be invoked is defined as a workflow or composite service in a standard notation (e.g. XML-based).

Prior to discussing the ‘invoke’ or ‘invocation’ as such the relation between Invoke SDS Service and Spatial Data Services needs to be considered. A conceptual view on this relation is presented in Figure 1.

⁴ INSPIRE Network Service Architecture Version 3.0, available under:

http://inspire.jrc.ec.europa.eu/reports/ImplementingRules/network/D3_5_INSPIRE_NS_Architecture_v3-0.pdf

⁵ see <http://www.w3.org/2002/ws/Activity> for related definitions, standards and recommendations

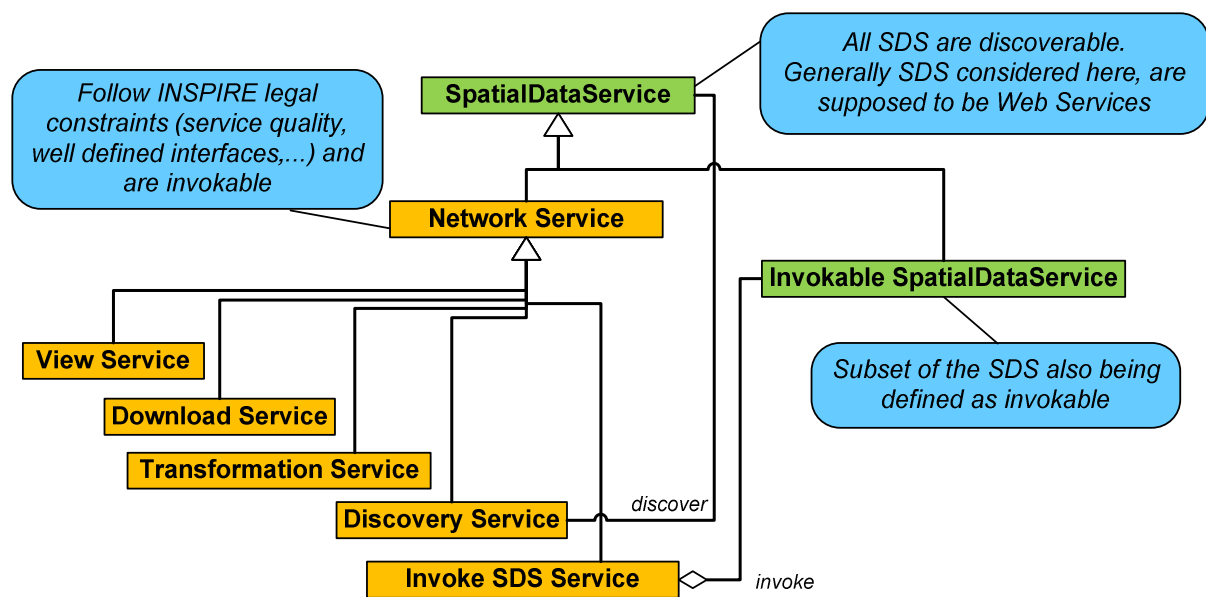

Figure 1: Conceptual Model of the INSPIRE Network Services (yellow; compliant to the INSPIRE Network Services Implementing Rule) and the Spatial Data Service (green, compliant to the INSPIRE Spatial Data Service Implementing Rule).

Following the directive *all* Spatial Data Services (SDS) that are related to the topics listed in the INSPIRE Annex I, II, III are described by INSPIRE Metadata. Thus SDS can be discovered via an INSPIRE discovery service (Figure 1).

In general Spatial Data Services cannot be expected to fulfil all rules defined for INSPIRE Network Services. In turn, conceptually the INSPIRE Network Services can be seen as a special sub-class of the INSPIRE Spatial Data Services fulfilling not only the obligation to be described via metadata but also fulfilling the requirements on provided functionality and service quality as described in the INSPIRE Network Services Implementing Rules. Thus, all Network Services are Spatial Data Services, but not all Spatial Data Services are Network Services.

'Invocation' is the application of the Invoke SDS Service to one or several Spatial Data Services. The interoperability arrangements for Spatial Data Services will be defined in the respective INSPIRE Implementing Rule (IR SDS), which is currently being investigated. It is assumed that not all Spatial Data Services can be invoked. A special subclass of the Spatial Data Services will be defined as *Invokable Spatial Data Services* (Figure 1). Invokable Spatial Data Services are expected to

- have a resource locator as defined in the metadata regulation (as a step towards allowing the request for execution of the Spatial Data Services).
- to have documented and well defined interfaces (e.g. as defined by the ISO TC 211 or OGC Web Service Interface Specifications)
- to provide a documentation of non functional properties (e.g. quality of service)

The Invoke SDS Services are considered as services that allow this subset of SDS to be invoked. Assuming that this does not necessarily mean that the Invoke Service runs or executes the SDS itself the Invoke SDS Services acts as an 'enabler' (e.g. by supporting the retrieval of the parameters needed for invocation).

The Invoke SDS Service is one of the five INSPIRE Network Service types (a specialisation of an abstract super class INSPIRE *Network Service*, Figure 1) and thus has to comply to the characteristics that have been defined for INSPIRE Network Services. This would mean that an SDS invoked by the Invoke SDS Service becomes accessible as a web service and similar to other INSPIRE Network Services. Thus an Invoke SDS Service could for instance enable the usage of a SDS within the European

Geoportal or any of the national Geoportals. The Invoke SDS Services are then meant to allow connecting SDS to the network service infrastructure for spatial information in Europe.

Accordingly the following definition of the Invoke SDS Service is proposed:

The *INSPIRE Invoke Spatial Data Services Service* enables the usage of an INSPIRE Invokable Spatial Data Service within the infrastructure of INSPIRE Network Services by supporting the binding (i.e. invocation) of one (or several) INSPIRE Spatial Data Service(s) into a service or an application similar to accessing the other INSPIRE Network Services.

A Spatial Data Service may be invoked as part of a sequence of events in the chain of presenting spatial data to a client from an organisational source (i.e. a data publisher). However the definition of service orchestration (also known as *service chaining*) is beyond the scope of the Invoke SDS Service IR.

Figure 2 presents the updated INSPIRE Service Architecture reflecting the notion of Invoke SDS Services, invocable Spatial Data Services and other (harmonized) Spatial Data Services as discussed above and in the corresponding recommendations on INSPIRE Spatial Data Services.

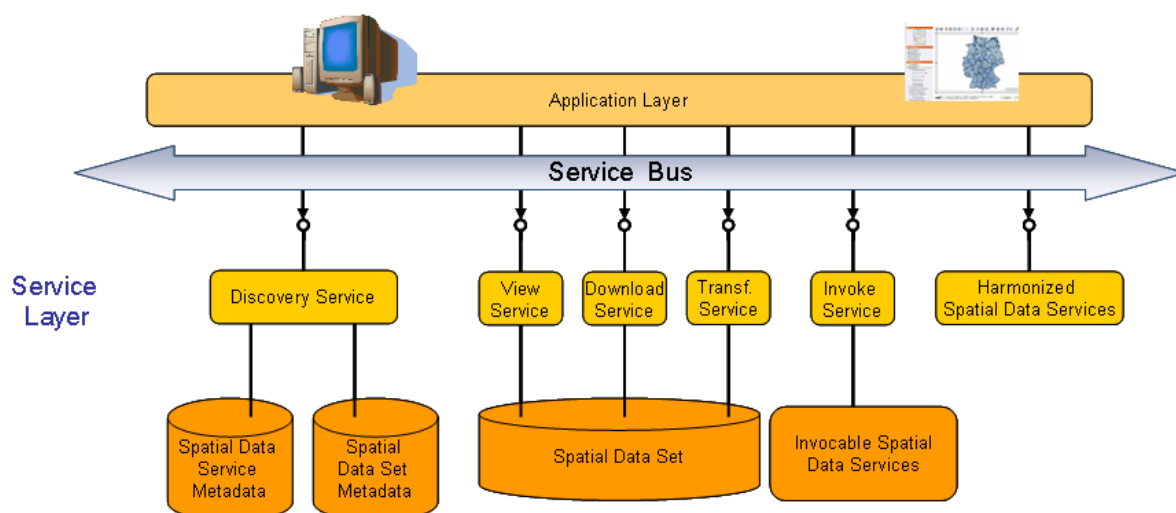

Figure 2: INSPIRE Invoke SDS Service and Spatial Data Services within the (updated) INSPIRE Network Service Architecture.

The following list illustrates potential usage scenarios of an Invoke SDS Service

- Géor@pports are documents that group together local information available in BRGM databases about geology and natural hazards. These documents are created on-line by the user who selects a location on a map. The service requests WMS to get maps and WFS to get data on a small area (about a few km² around the selected point) and insert this information in a pdf file. Information that could be provided is:
 - A topographic map
 - A geological map
 - Maps and data (tables) about previous earthquakes, landslides, underground cavities, industrial sites
 - Link to legal documents to prevent risks

The users are the citizen, the companies but also notaries who have to inform the buyer of a property on the possible underground pollution by a previous industry

More on the web site (in French): <http://www.brgm.fr/georapport.jsp>

- The DeepCity3D project intends to develop viewing tools to integrate city models and underground data (provided in standardised formats). These tools shall support managing underground issues (management of networks, underground water levels, mechanical properties of soils, presence of cavities, etc).

A first step is to develop a WPS to take as input information on buildings (described according the standard CityGML), to add information about building foundations, and to deliver enriched data on buildings (also in CityGML format). In a next step more input data about the underground (like geology and boreholes data, also according to the standard GeoSciML) will be considered.

More on the project web site: <http://www.deepcity3d.eu/default.aspx>

- Imagine an Invoke SDS Services enabling the usage of a number of Spatial Data Services to allow the calculation of the total area of protected sites being affected by a planned site (industrial, urban, energy,...). Whereas the site is given as a GML-defined geometry (as a data stream or as a result of online digitizing) that possibly requires coordinate transformation (been realised by an INSPIRE Transformation Service also been linked into the Invoke SDS Service)

Clearly any client application could act as an 'invoke spatial data services' mechanism but, an Implementing Rule should reduce to specify a Service Interface of an invoke SDS service (Figure 3).

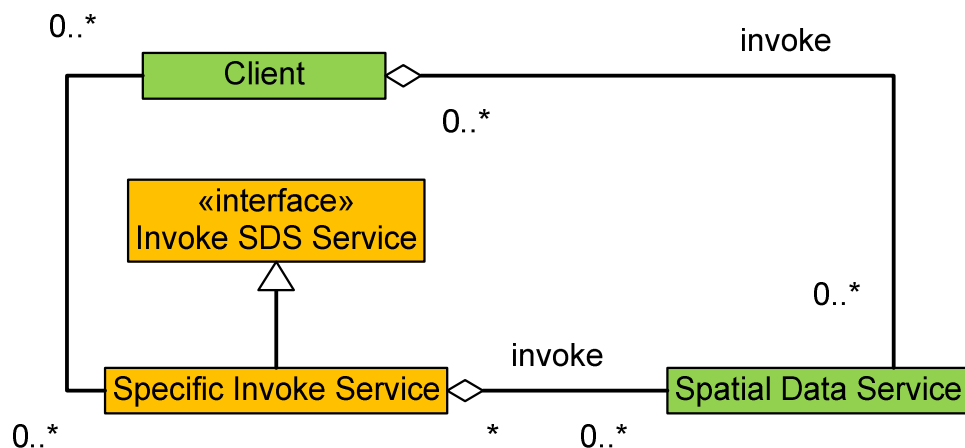

Figure 3: The Invoke SDS Service Implementing Rule focuses on the definition of a service interface (yellow) which is then fulfilled by a specific implementation of that interface i.e. a Invoke Service Instance (Specific Invoke Service).

If an INSPIRE Register (as proposed in the INSPIRE Network Service Architecture, see also **Error! Reference source not found.**) is realised, the Technical Guidance Document for the Invoke SDS Service could also propose to register the (technical) interface specification(s) of the Invoke SDS Service in that INSPIRE Register.

2.2 Analysis of potential technologies for INSPIRE Invoke SDS Services

A survey and critical analysis of existing Standards and Methods to define and support invocation of Spatial Data Services should consider the following aspects:

1. Existing Standards and Methods to define Web Service Invocations; especially to allow automatic invocation
 - Which standards and formal description methods do exist

| | | |
|--|---------------------------------------|--------------|
| Infrastructure for Spatial Information in Europe | Position Paper IR Invoke SDS Services | |
| | 2011-10-08 | Page 9 of 12 |

- Where (in which field) do they get applied
 - How far can they be considered consolidated and accepted (with a special consideration of eGovernment applications)
 - Which of these Standards possibly support services or applications in the spatial domain
 - Or: would an extension to the spatial domain (easily) be possible
 - which are the specific communication pattern
 - synchronous or asynchronous; push or pull
 - which ways do exist to realize and control the flow of (spatial) data with the specific consideration of larger (spatial) data amounts
 - The consideration should include SOAP/WSDL, BPEL, WSC(I), OGC WPS
2. Existing tools/engines etc. exist to use these standards (COTS, OTS, Research)
- Where (in which field) do they get applied
 - How far can they be considered consolidated and accepted (with a special consideration of eGovernment applications)
 - Which of these tools possibly support services or applications in the spatial domain
3. Discuss Service Level Agreements (SLA) in a distributed environment including Quality of Service aspects:
- SLA for the invoked services
 - SLA for the invocation services
 - Possible requirements on the network/infrastructure

Further input to these considerations is expected, once a related and on-going technical study is finalised.

2.2.1 Possible technologies and tools

The study 'Status for the Invocation of INSPIRE Spatial Data Services' which has been recently launched and just finalised. This study lists and discuss the technical solutions which are available to for INSPIRE Spatial Data Services invocation and form valuable input for the drafting of the Technical Guidance for INSPIRE Invoke SDS Service. Basically the report recommends using the OpenGIS Web Services and SOAP/WSDL as the underlying technical interface specifications.

2.3 Operations and service quality requirements of an INSPIRE Invoke SDS Services

Following suggestions made in the JRC Technical Report on Invoke SDS Services from 2009⁶ **Error! Reference source not found.** sketches the possible operations of an INSPIRE Invoke SDS Service.

⁶ Lucchi, R; Millot M. (2009):INSPIRE Invoke SDS Services Survey on requirements, challenges and recent research findings supporting the development of the Invoke spatial data service specification. European Commission DG JRC Scientific and technical report. Available under <http://inspire.jrc.ec.europa.eu/>.

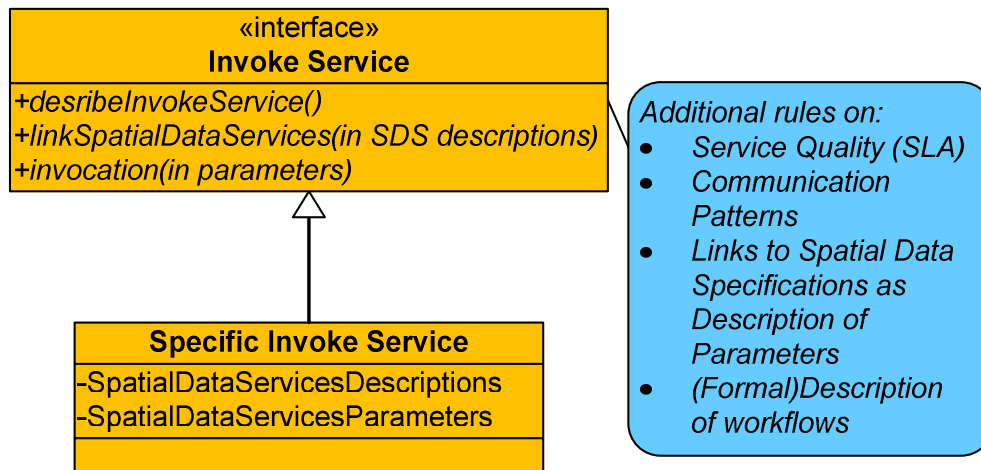

Figure 4: Definitions for Invoke SDS Service Operations.

These operations are intended as:

| Operation | Description |
|--|---|
| describeInvokeService() | Provides Metadata allowing the usage and binding of the Invoke SDS Service. Especially, the parameters that need to be handed to the invoke operation get detailed here. |
| linkSpatialDataServices(in SDS Descriptions) | <p>Allows linking one or several Spatial Data Services into the Invocation workflow.</p> <p>Accordingly, the input parameter contains the descriptions on how the Spatial Data Services can be invoked (e.g. URL, name and domain of parameters, etc.). In the case of an invocation of more than one Spatial Data Service also the sequence of the invocation is defined. The operation returns a status parameter reporting about the success or non-success of the link operation.</p> <p>As stated above (automatic) service orchestration is beyond the scope of the implementing rule. However in form of an aggregated service as defined in EN ISO 19119 it is also possible to provide an invoke access to a series of services which are executed in closely coupled sequence by this aggregated service.</p> <p>Note: Parameters could be one or many.</p> |
| invoke(in parameters) | <p>Allows the invocation (i.e. execution) of the linked Spatial Data Services. The parameters required to control or initialise the (sequence of) Spatial Data Services are handed to the invoke operation as detailed in the service metadata (describeInvokeService).</p> <p>Note: Parameters could also be an empty set.</p> |

Basically these operations would support the well known publish- find-bind paradigm for a given Spatial Data Service as follows:

- *publish SDS* is realised via `linkSpatialDataServices`

Typically a provider of a Spatial Data Service would fulfil this operation and this way provide all the metadata being necessary to use (i.e. invoke) the service by any interested service user.

- *find SDS* is supported via `describeInvokeService`

Once all the metadata for a Spatial Data has been published with the operation above, any user could browse for the invocable Spatial Data Services via an INSPIRE discovery service and inspect the capabilities of these services.

- *bind SDS* is realised via `invoke`

This would then equal the usage of a concrete (invokable) Spatial Data Service by a user.

Moreover It is proposed to discriminate two ways of realising an INSPIRE Invoke SDS Service (similar to the two ways of the download service):

1. **non-mediated invocation:** invoke (directly) an INSPIRE Spatial Data Service instance
2. **mediated invocation:** invoke an INSPIRE Spatial Data Service via an INSPIRE Invoke SDS Service instance if a mediation for invocation is needed

The first option (non-mediated invocation) would require that an INSPIRE SDS instance would be equipped with sufficient service metadata and a well defined way on how to hand-over parameters; such a way that the service instance becomes easily accessible and linkable to the INSPIRE Network Service Infrastructure

The proposed operations of an Invoke SDS Service could then be realised as:

| | non-mediated invocation | mediated invocation |
|--|---|--|
| describeInvokeService ('find') | The SDS IR should define the related Service Metadata | Wrap access to the Metadata of one or several SDS |
| linkSpatialDataServices ('publish') | Making the service metadata of a SDS accessibly via an INSPIRE Discovery Service such that a SDS can be invoked | Allows linking one or several Spatial Data Services into the Invoke SDS Service. |
| invoke ('bind') | Invoking an SDS to execute the SDS using its existing interface | Wrap access to an SDS via an invoke operation, such that it can get invoked as the other INSPIRE NS |
| Quality of Service | The Quality of the invocable, non-mediated SDS needs to be documented in the metadata and needs to be adhered to by the respective SDS. | Availability as the other INSPIRE NS The Quality of the mediated SDS needs to be documented in the metadata. And needs to be adhered to by the respective SDS. Here the Quality of Service description needs to consider the invoke SDS Service as well as the SDS Service. It should be guaranteed that the Invoke SDS Service (i.e. the mediation) does at least fulfill the same Quality of Service requirements as the mediated |

| | | |
|--|--|------|
| | | SDS. |
|--|--|------|

2.4 Quality of Service

The *Quality of Service* Criteria to be defined for Invoke SDS Services are considered comparable to criteria typically being defined in Service Level Agreements (SLA) and should cover the following aspects:

- Performance
- Capacity
- Availability

The quality criteria being defined for an Invoke SDS Service should *not* include the quality of service of the invoked SDS. This way it should be ensured that quality of an Invoke SDS Service can be granted (and monitored) independently from any invoked SDS.

2.5 Roadmap towards an Implementing Rule of INSPIRE Invoke SDS Services

The following roadmap is proposed to develop the Invoke SDS Service Implementing Rule:

| Milestone | Deliverable |
|-----------|--|
| 10/2011 | Finalised NS DT Position Paper (Vs. 3.0) on INSPIRE Invoke SDS Service (together with the finalised SDS Recommendation Paper) |
| 12/2011 | Version 1 of the draft Implementing Rule on INSPIRE Invoke SDS Service and recommendations on the Guidance Documents (synchronised with draft Implementing Rule on INSPIRE SDS) for discussion internal to the Drafting Teams |
| 5/2012 | Version 2 of the draft Implementing Rule on INSPIRE Invoke SDS Service recommendations on the Guidance Documents (synchronised with draft Implementing Rule on INSPIRE SDS) for discussion with the SDIC/LMOS and National Contact Points (n the frame of the INSPIRE conference 2012) |
| 12/2012 | Version 3 of the draft Implementing Rule on INSPIRE Invoke SDS Service recommendations (synchronised with draft Implementing Rule on INSPIRE SDS) to be handed to the EC and to be prepared for the INSPIRE Committee. |